

---

# ***A Never Forgotten Incident***

***Submitted by Stan Hutchins  
Original story by Gladwyn E Pinkston***

*During the invasion of China by Japanese in 1935, the military forces of the Republic of China, under General Chiang Kai-shek, as a matter of necessity, joined forces with their bitter enemy, the communists, under General Mao Ze don". The Japanese surrendered in 1945 and withdrew from China. Almost immediately, the Chinese Communists and the Nationalists resumed hostilities. It soon became apparent to the Nationalists that they were losing the war. Some 350,000 of them retreated to Formosa-now called Taiwan. The exodus used many different ships and also large numbers of cargo/transport C-47 aircraft that were given to them by the U.S. during the war with Japan.*

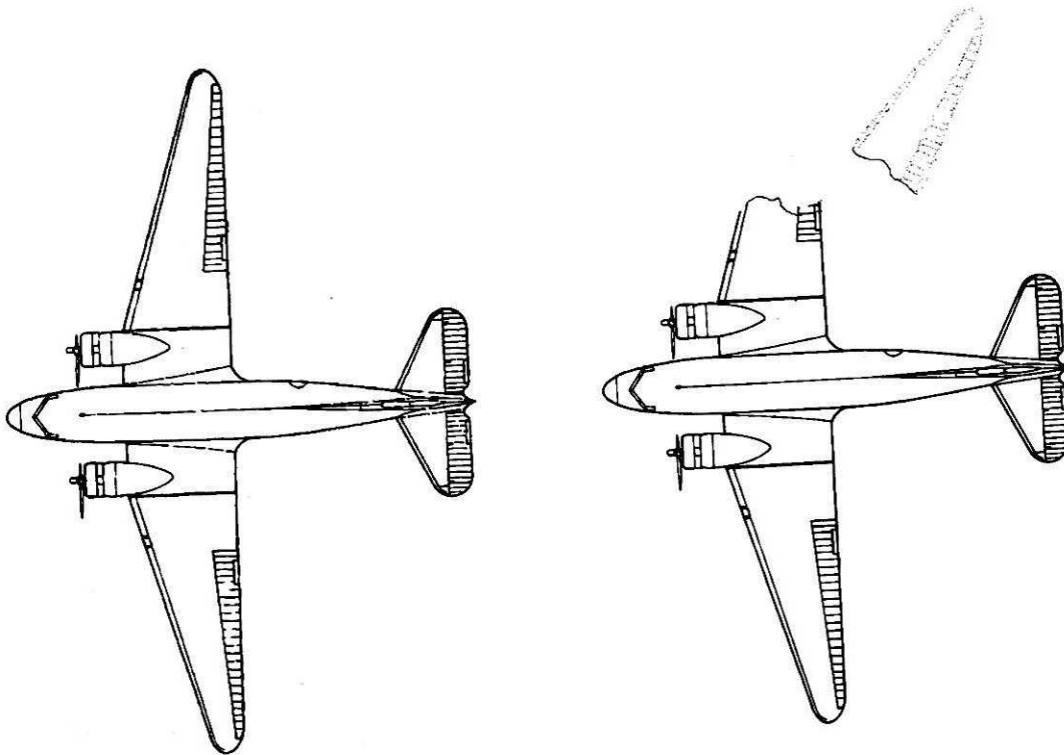

## ***The Story Begins In Taipei, The Capital Of Taiwan***

The United States had established a military presence in Taiwan. The Air Force part of that presence was Air Task Force 13. I was privileged to be the Commander. In April 1964, General Hsu Huan Sheng, Commander of the Chinese Air Forces, called and said, "Pinky, General McElroy and his wife are coming on a visit next week and we would like to entertain them. Would you please

escort them down Island to Taroko Gorge? They will be flying in our VIP C-47." Of course I said that I would be glad to. A word about this C-47. It was probably around 20 years old but it was immaculately maintained. The cabin interior was as beautiful and plush as the finest civilian airliner and the crew included Chinese hostesses. The pilot was a fine looking officer of perhaps 45 years